



HRL-0025-1 HEATLESS DESICCANT AIR DRYER GENERAL ARRANGEMENT

TOLERANCES UNLESS
OTHERWISE SPECIFIED:

- FRACTIONS = ± 1/4 "
- ANGLES = ± 3°
- INCHES = ± 1/2 "
- FINISH = 250

THE SPECIFICATIONS AND DRAWINGS DISCLOSED HEREIN ARE THE SOLE PROPERTY OF ALTEC AIR, AND SHALL NOT BE COPIED OR USED AS THE BASIS FOR SALE OR MANUFACTURE WITHOUT EXPRESS WRITTEN PERMISSION.

REVISION LOG

REV.	ECO.	DESCRIPTION	DATE	APPROVED
F	1182	CHANGED TO 6" X 21" TANKS	9/20/2021	WS

DRAWING NO.

AT20-508

REV.
F

DRAWN: MR DATE: 2/9/2015
CHECKED: DATE:

SCALE: N/A SHEET: 1 OF 2

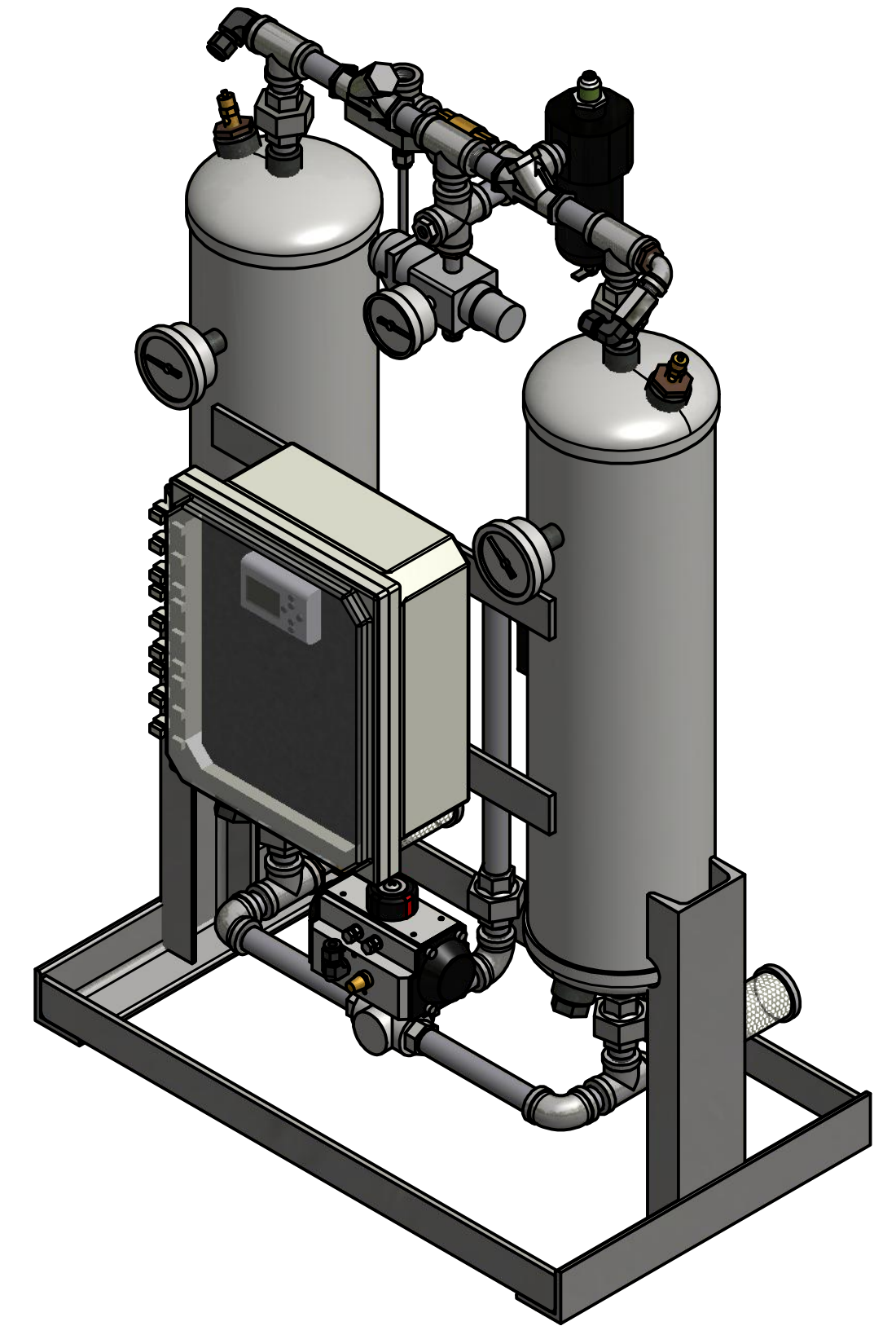
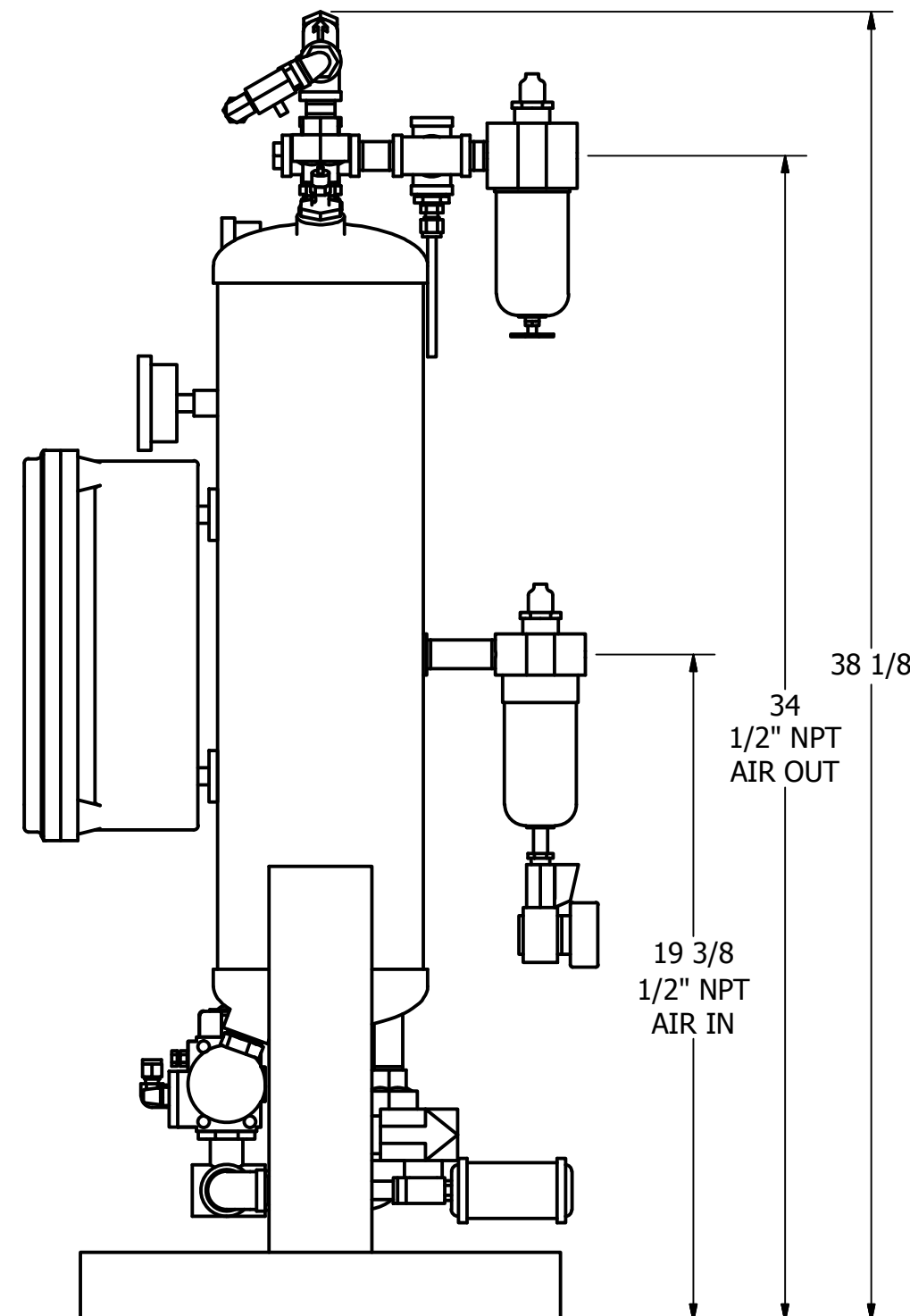
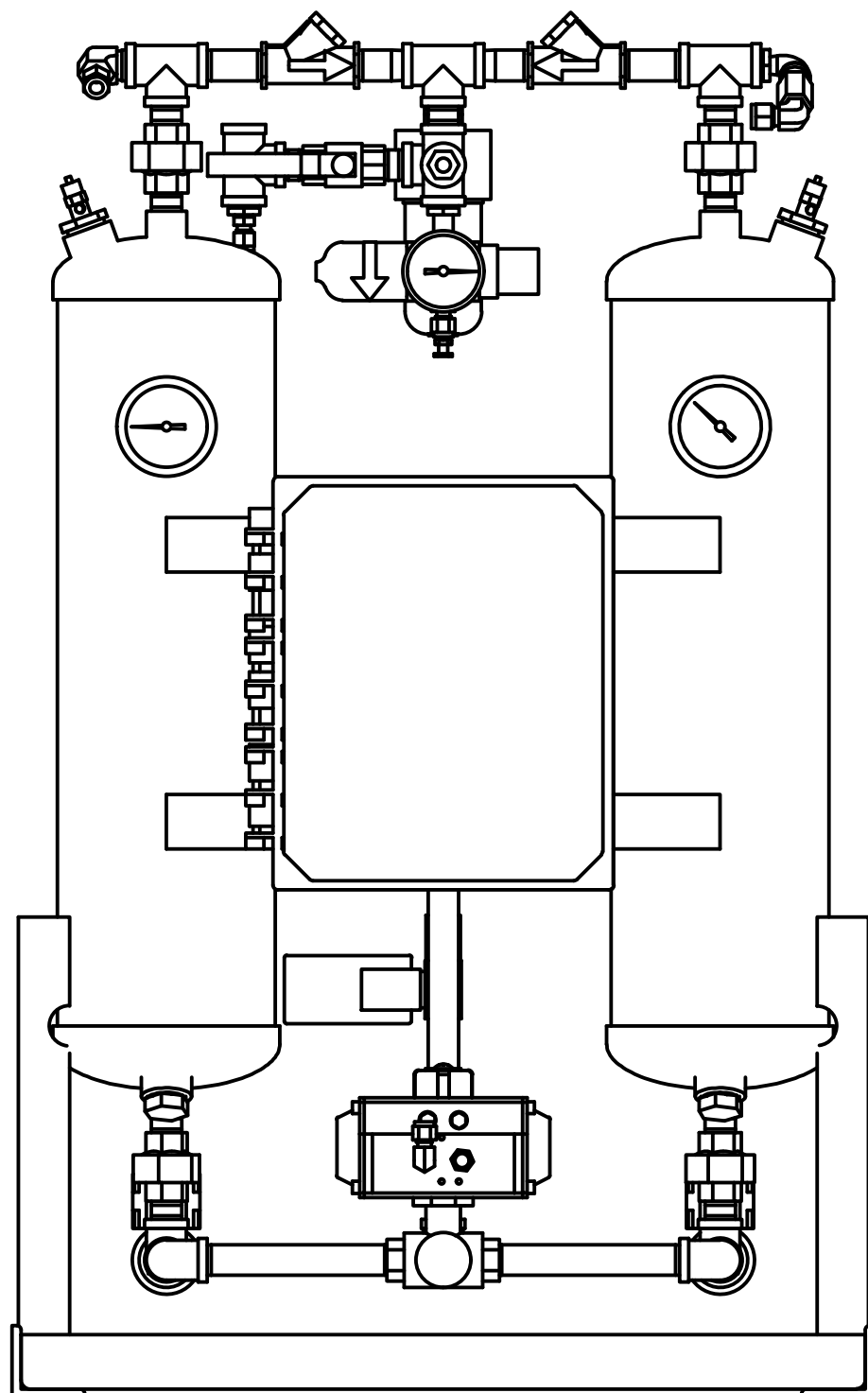
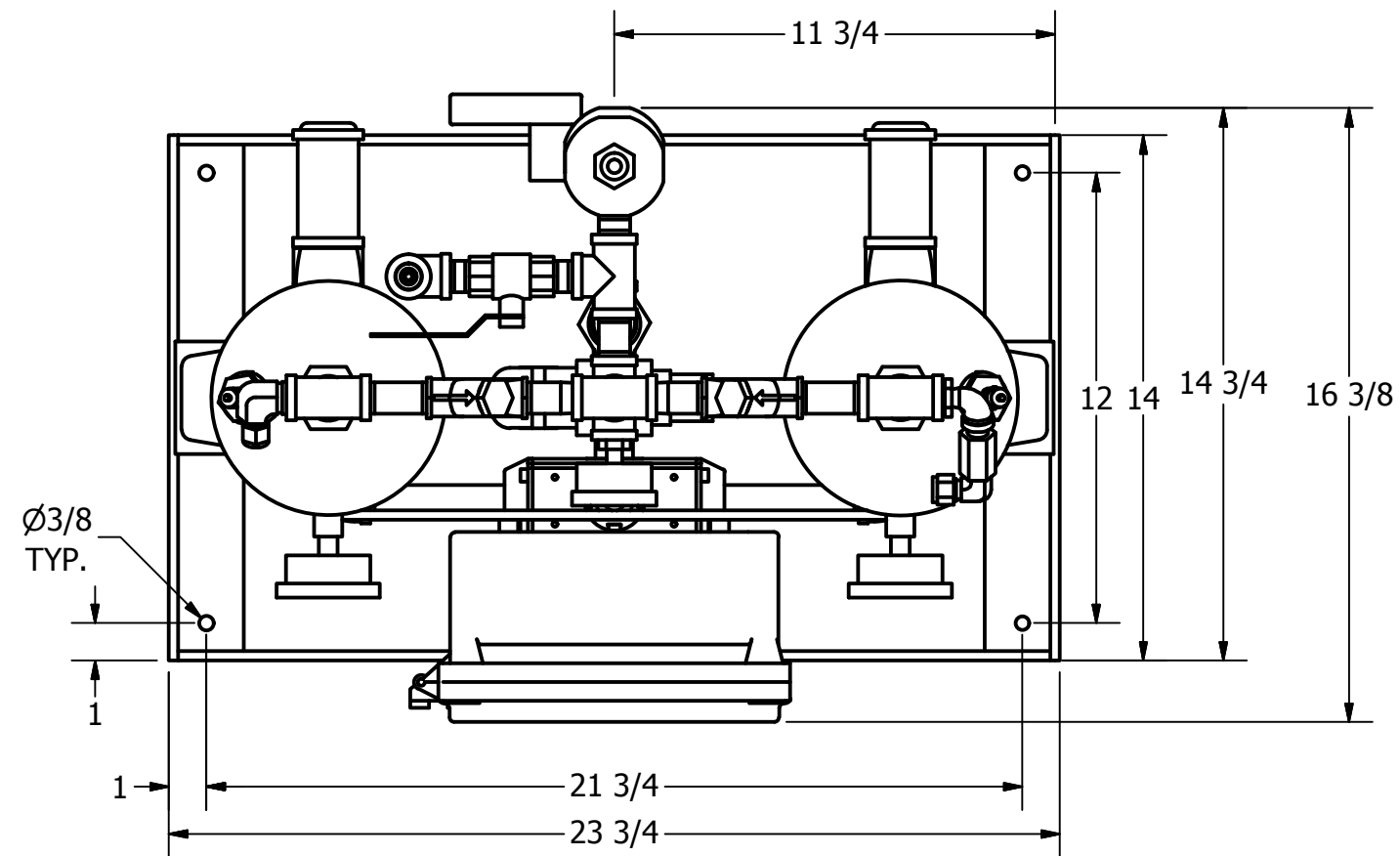

PRELIMINARY



HRL-0025-1 HEATLESS DESICCANT AIR DRYER GENERAL ARRANGEMENT

TOLERANCES UNLESS
OTHERWISE SPECIFIED:

FRACTIONS = ± 1/4 "
 ANGLES = ± 3°
 INCHES = ± 1/2 "
 FINISH = 250

THE SPECIFICATIONS AND DRAWINGS DISCLOSED HEREIN ARE THE SOLE PROPERTY OF ALTEC AIR, AND SHALL NOT BE
 COPIED OR USED AS THE BASIS FOR SALE OR MANUFACTURE WITHOUT EXPRESS WRITTEN PERMISSION.

REVISION LOG

REV.	ECO.	DESCRIPTION	DATE	APPROVED
F	1182	CHANGED TO 6" X 21" TANKS	9/20/2021	WS

DRAWING NO. **AT20-508** REV. **F**

DRAWN: MR DATE: 2/9/2015
 CHECKED: DATE:

SCALE: N/A SHEET: 2 OF 2

PARTS LIST

ITEM	QTY	DESCRIPTION
1	2	CHECK VALVE, OUTLET
2	1	DEW POINT MONITOR (OPTIONAL)
3	1	PARTICULATE AFTER-FILTER
4	1	MOISTURE INDICATOR
5	1	PRESSURE REGULATOR, CONTROL
6	1	PRESSURE GAUGE, CONTROL
7	1	BALL VALVE, PURGE
8	2	PRESSURE GAUGE, TANK
9	1	3-WAY BALL VALVE, INLET
10	1	COALESCER PRE-FILTER
11	1	TIMER DRAIN
12	2	SOLENOID VALVE, EXHAUST
13	2	MUFFLER, EXHAUST
14	2	RELIEF VALVE, TANK
15	30 LBS	DESICCANT

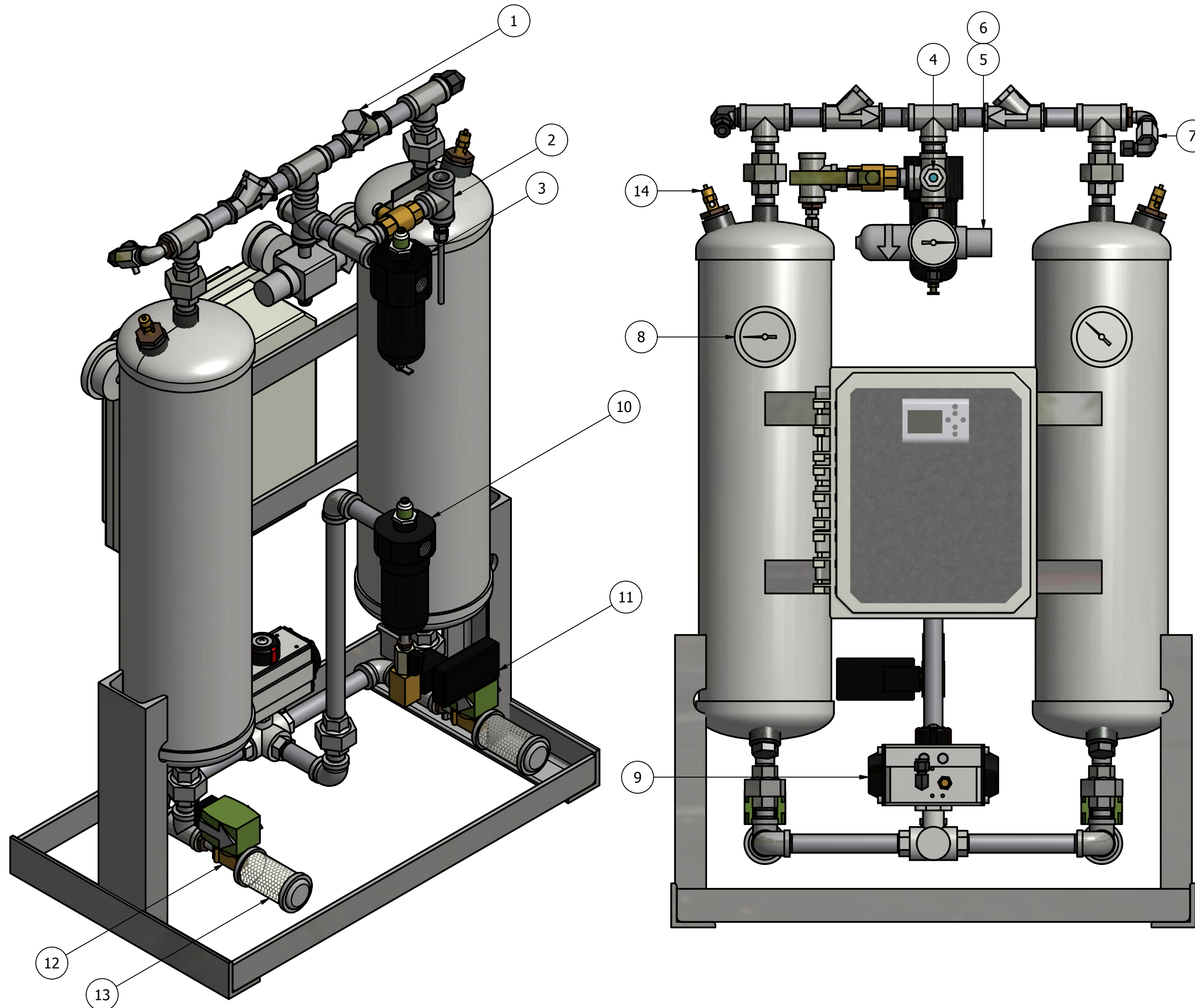

PRELIMINARY